

MODEL

# 58BD & 58BW

## Parts List and

Portable/Convertible  
Manual Bandsaw

Built better to work stronger and last longer

## Operating & Maintenance Manual

starting sn 25053



REV 190501



**Wellsaw**<sup>®</sup>  
Made In The USA

Quality Metal Cutting Bandsaws

2829 N. Burdick St. Kalamazoo, MI 49004

Phone: 269-345-1132 Fax: 269-345-0095

[www.wellsaw.com](http://www.wellsaw.com)

# Index

Specifications ..... 2  
 Warranty Info ..... 2  
 Safety Instructions ..... 3  
 Operation & Maintenance ..... 5  
 Recommended Service Kit ..... 7

**Parts Drawings & Parts Lists**

Bed & Leg ..... 8-9  
 Wheel & Frame ..... 10-11  
 Blade Guide & Gear Box ..... 12-13  
 Coolant, Switch & DashPot ..... 14-15  
 Service Parts Changes (Before Serial # 22020)..... 16  
 Switch Box Assembly ..... 16

**Trouble Shooting** ..... 17

Electrical Schematic ..... 18

**Wellsaw® Select-O-Chart** ..... 20-21

# Specifications

## Horizontal Capacity for current model\*

Rectangular .....	9.5" H x 11"W
Round.....	9.5"Diameter
Flat.....	12"
45 Degree Angle.....	5-1/2"H x 5-1/2"W

## Vertical Capacity

Work Table.....	8" x 10"
Throat Height.....	9-1/2"
Throat Depth.....	6-1/4"
Speeds, FPM.....	76, 141, 268
Blade Size .....	1/2" x .025" x 7'-9" (93")
Motor .....	1/2 HP
Bed Width.....	8-1/2"
Floor to top of bed .....	26"
Floor space.....	26" x 54"
Height (Frame Vertical).....	55-3/4"
Height (Frame Horizontal) .....	42-3/4"
Approximate Shipping Weight, 58BD .....	350 lbs
Aproximate Shipping Weight, 58BW .....	365 lbs.

Additional blades available:  
 6, 10, 14, 18 & 24 teeth per inch

# Full Year Limited Warranty

This WELLSAW is warranted against defects in material or workmanship installed or performed at the factory. Within one year fro, date of purchase, we will free of charge and at our option, either repair or replace any part of this WELLSAW which our examination discloses to be defective because of workmanship or a defect in the material. This warranty does not apply if this WELLSAW has been used in a manner not consistent with its' design or which has been subject to accident, alteration, abuse or misuse or which fails due to lack of care or is the result of inadequate power supply and specifically does not apply to normal wear parts. **THERE ARE NO WARRANTIES WHICH EXTEND BEYOND THE DESCRIPTION OF THE FACE HEREOF.**

WELLSAW shall not be liable for consequential or incidental damages suffered or incurred with respect to defective materials or workmanship.

We do not authorize any person or representative to make any other warranty or to assume for us any liability in connection with the sale of our products other than those contained herein. Any agreements outside of or contradictory to the foregoing shall be void and of no effect.

All transportation costs on products or parts submitted to WELLSAW under this warranty must be paid by the user. No products or parts are to be returned without first obtaining permission

**\* previous versions of the Model 58B have had smaller capacities:**

serial numbers	capacity	angle	start year
start to sn 11884	6" x 10"	38	1958
11885 to 23617	7" x 11"	42	1970
23618 to present	9.5" x 11"	60	1997

## For Your Convenience

When contacting your WELLSAW supplier or the Company for parts or service, it is helpful to have both your saw Serial Number and Purchase Date available. Jot them down her for handy reference.

**Serial Number:** \_\_\_\_\_

**Purchase Date:** \_\_\_\_\_

---

# SAFETY INSTRUCTIONS

## Know your machine, its safe and proper use!

---

**DISCONNECT POWER** before adjusting or servicing the saw or changing a blade.

**STAY CLEAR** of all moving parts. Keep hands and fingers away from the saw blade.

**WHEN MOVING SAW**, with hinged frame (saw head), secure the head in its down position.

**WHEN CUTTING MAGNESIUM**, take special precautions. Use a sharp saw blade, make only dry cuts, prevent chip accumulation, and keep fire-fighting equipment nearby.

**THIS SAW SHOULD BE GROUNDED WHILE IN USE TO PROTECT THE OPERATOR FROM ELECTRICAL SHOCK.**

**CORD CONNECTED TOOLS.** If the saw is equipped with an approved 3-conductor cord and a 3-prong grounding type plug, it should only be connected to a properly equipped and grounded receptacle. The green conductor in the cord is the grounding wire. Never connect the green wire to a live terminal.

Use only a 3-wire extension cord having a 3-pronged receptacle, a 3-pronged plug and ample amperage rating. Replace or repair a damaged or worn cord immediately.

**PERMANENTLY CONNECTED TOOLS.** The saw should be connected to a grounded, metal-enclosed wiring system or an equipment-grounding conductor should be run with the circuit conductors and connected to the saw's grounding terminal or lead.

To reset the manual starter after a power interruption, return the switch to OFF and press the RESET button before restarting.

### FOR ALL TOOLS

**KEEP GUARD IN PLACE** and in working order.

**REMOVE ADJUSTING KEYS AND WRENCHES.** Form a habit. Check to see that all keys and wrenches are removed from the tool before turning the tool on.

**KEEP WORK AREA CLEAN.** Cluttered areas and benched invite accidents.

**AVOID DANGEROUS ENVIRONMENT.** Do not use power tools in damp or wet locations. Keep your work area well lighted.

**KEEP CHILDREN AWAY.** All visitors should be kept a safe distance from work area.

**MAKE WORKSHOP KID-PROOF** with padlocks, master switches, or by removing starter keys from tools.

**DON'T FORCE TOOL.** It will do the job better and safer at the rate for which it is designed

**USE RIGHT TOOL.** Don't use a tool or attachment to do a job for which it was not designed.

**WEAR PROPER APPAREL.** No loose clothing or jewelry to get caught in moving parts. Rubber-soled footwear is recommended for best footing.

**USE SAFETY GLASSES.** Also use face or dust mask if operation is dusty.

**SECURE WORK.** Use clamps or a vise to hold work. Provide adequate support to prevent injury from falling work pieces.

**DON'T OVER REACH.** Keep proper footing and balance at all times.

**MAINTAIN TOOLS WITH CARE.** Keep tools sharp and clean for best and safest performance. Follow instructions for lubricating and changing accessories.

**DISCONNECT TOOLS** before servicing or when changing accessories such as blades, bits, cutters, etc.

**AVOID ACCIDENTAL STARTING.** Make sure the switch is in OFF position before connecting power tools.

**USE ONLY RECOMMENDED ACCESSORIES.** Consult the owner's manual for recommended accessories. The use of improper accessories may be hazardous.

**NEVER STAND ON A TOOL.** Serious injury can occur if the tool is tipped or the cutting tool is accidentally contacted.

**CHECK DAMAGED PARTS.** Before further use of the tool, a guard, or other part that is damaged, should be carefully checked to ensure that it will operate properly and performed its intended function. Check for alignment of moving parts, breakage, mounting and any other condition that may affect the tool's proper operation. Any guard or part that is damaged should be properly repaired or replaced.



This excerpt from a survey report does not necessarily reflect the views and policies of OSHA however it is presented for your consideration in maintaining workplace safety.

From  
**“Machine Guarding -  
Assessment of Need”**

HEW publication No. (OSHA) 75-173

**SUMMARY:**

The previous information discussed specific machines and their inherent characteristics and hazards. All machines, however, require proper power installation and maintenance. High-speed, rotating cutting tools must be properly sharpened and well balanced to eliminate vibration. Saw blades must be properly sharpened and set to eliminate binding and ensure clean cuts. Any cutting tool that is cracked or chipped must be discarded.

The work area should be neat, well lighted, properly ventilated and free of pedestrian or vehicle traffic. Ample room is needed for stock handling and storage, the floors must be free of slipping or tripping hazards as many machines have exposed tooling that can be fallen on.

These items, though they are not specific machine guard needs, are equally important.

It is also interesting to note that operators observed and questioned by the survey representatives and employed on some woodworking and metalworking equipment are often new hires with little or no experience with machine operation. This is substantiated by the finding that proper training programs are almost absent from industry (Field Supplement, page 8) and by the fact that the highest percentage of accidents occurs at a young age (see Field Survey Supplement, page 8). The best example of this is with operators of saws where the operation seems self-explanatory through observation. Perhaps the operation is basically simple; nevertheless, operators should be carefully trained and enthusiastically motivated to perform safely.

A final observation found through field surveys has to do with the size of the company versus the number of unguarded machines (see Field Survey Supplement, page 2). The smaller the company in number of employees, the larger the percentage of unguarded machines observed. This illustrates a further need for machine guards.

The age of the operator, the size of the company, and the lack of training programs, along with the investigation of specific machines to identify inherent hazards, establishes a definite need for machine guarding. The fact that a hazard exists and a worker performs in proximity to that hazard will undoubtedly result in an injury. Because of this, the use of machine guards to divorce the operator from the hazard to the highest possible degree is not only desirable but needed. It is the moral responsibility of the employer and expected benefit to the employee to be able to manufacture goods without occupational injuries.

---

# Operation & Maintenance

---

## READ CAREFULLY

The MODEL 58B METAL CUTTING BAND SAW is designed for efficient performance. With proper care, it will give you many years of dependable service. **READ THIS MANUAL CAREFULLY BEFORE OPERATING YOUR NEW SAW.**

After final assembly, each saw is inspected and tested. No adjustment should be needed.

This manual has been prepared to assist you in the operation and maintenance of your new saw. If you desire additional information or assistance, please contact your dealer's service representative.

## INSTALLATION

Uncrate and check all parts. Report any damage to your carrier and file a Proof of Loss Claim with the carrier.

Be sure motor specifications correspond with your power source.

Place the saw so that each leg is carrying its share of the load. The 58B Saw can be operated horizontally and vertically. For vertical operation, place frame in upright position, attach the vertical work table and, operate switch manually.

## OPERATION

Do not apply too much feed rate. Start cut carefully and the new blade will last much longer. Make sure all four legs are in solid contact with the floor. Keep blade guide as close to the work as possible.

## PLACING BLADE ON SAW

- 1a. **DRY CUTTING MACHINE.** Release from safety latch bar and swing frame into vertical position.
- 1b. **MACHINE WITH WET CUTTING SYSTEM.** Remove chip pan, then follow instructions in 1a.
2. Open idler wheel hinged guard.
3. Remove blade guard.
4. Turn blade tension wing screw to lower the idler wheel and slide block assembly.
5. Uncoil a 1/2" x 93" blade.
6. When facing cut-off side of machine, blade must travel toward the motor end.
7. Be sure blade teeth point in this direction. If not, twist blade band inside-out.
8. Install blade as follows:
  - a. Place blade between guide bearings and brushes.
  - b. Insert blade into slot between frame and guard.
  - c. Slide blade onto the drive and idler wheels.
  - d. Turn tension wing screw until blade is taut.

9. Briefly start and stop motor a few times to make sure blade is riding correctly on band wheels, then tighten blade to proper operating tension.
10. Replace blade guard.
11. Lower frame for horizontal cutting.
12. Check safety bar. Be sure it is in proper position to prevent frame from being raised beyond maximum position when used as a horizontal cut-off saw.

## QUICK ACTION VISE

The sliding vise jaw is equipped with a ratchet dog arm for quick action and a hand wheel for tightening work in the vise. Excessive pressure is not required to hold material securely in the vise.

## FIXED JAW VISE

Two pins in the fixed vise jaw assist in the quick relocation of the fixed vise jaw for 90° cutting. For final and accurate adjustment, the blade should be squared with the vise jaw by placing machinist's square head lightly against the side of the blade and the squares blade against the machined face of the vise jaw.

**NOTE:** These pins must be removed before fixed vise jaw can be turned. For angle cutting, use the clamp bolts to hold fixed vise jaw.

Loosen sliding vise jaw and push against fixed jaw vise jaw, then cap screw tightened, leaving vise jaws parallel.

## MAXIMUM VISE CAPACITY & 45° ANGLE ADJUSTMENT

1. Remove blade brush assembly from blade guide arm.
2. Remove the two 5/16" cap screws holding guide arm to the frame.
3. Move guide arm back to the next two holes. Replace cap screws and tighten in place.
4. Remove vise jaw pins in fixed vise.
5. Remove 1/2" cap screw from quadrant.
6. Loosen cap screw in center of vise jaw and slide vise toward motor end of machine about 2-1/4".
7. Replace 1/2" cap screw in tapped holes and tighten lightly.
8. With saw frame in cut-off position, place head of machinist's square lightly against slot in bed with the blade of square against machined face of vise jaw. Tap lightly with lead hammer until vise jaw is parallel to blade of square. Tighten cap screws. Use a protractor for angle adjustment.

## DASH POT

Wellsaws are equipped with a dash pot (frame check) to stabilize the downward travel of the saw frame to protect the saw blade from damage. The action is hydraulic. The flow of fluid being bypassed through an orifice controls the downward stroke of the saw frame.

Fill the dash pot to within 1" of top of the bottom of cylinder with Cities Service "Amplex 05" Hydraulic Oil or equivalent.

## FRAME WEIGHT ADJUSTMENT

The position of the collar in relation to the spring on the dash pot acts as the frame weight adjustment.

The proper frame weight is approximately 10 lbs. and is obtained by positioning the collar 3-3/4" down from the top edge of the *upper* cylinder to the top edge of the collar. For less frame weight, loosen collar and move downward toward tension spring. Reverse procedure for more frame weight.

Too much frame weight will cause the blade to cut crookedly.

## SWITCH AND MOTOR

This saw is equipped with a start-stop switch that automatically shuts off the motor at the completion of a cut when the wheel guard contacts the switch control lever to the desired position for proper shut-off.

It is necessary to raise the saw frame clear of the switch control lever before the saw can be started.

Thermal overload protection is provided in the motor. Should the motor stop for other than normal reasons, it may be due to overload. After the problem has been corrected, the motor may be reset by following the instructions on the motor name plate.

## SPEED SELECTION

Saws are equipped with step pulleys that provide three speeds: 76, 141 and 268 blade feet-per-minute. Change blade speed by loosening wing screw close to the motor pivot. Place belt in desired position, tighten wing screw until belt is snug and lock wing screw with wing nut.

**FAST** speed to cut thin-wall metal, tubing, thin brass or any metal that will not burn teeth.

**MEDIUM** speed on general cutting such as cold rolled machine steels or any metals which require a slow speed on a lathe.

Use beeswax when cutting brass. Brass should always be cut with a new blade. If teeth wear unusually fast, use slower speed. Always keep the blade in proper tension.

## MAINTENANCE

**BEFORE MAKING ANY ADJUSTMENTS, ALWAYS TRY A NEW BLADE TO MAKE SURE THE CAUSE OF THE PROBLEM IS NOT A WORN BLADE.**

Blade guides are provided to hold the blade in both horizontal and vertical alignment.

Accuracy of cut depends on proper adjustment of the blade bearings. Check their condition for wear or a tendency to stick. When the blade is moved sideways or with a twisting action, the movement should stop at the bearings and not be transferred beyond this point.

An eccentric axle is provided on each blade guide. By rotating this axle, the bearing is drawn away from the blade.

## WHEEL PITCH ADJUSTMENT

If the blade runs too low on wheels, it may be because of too much blade tension. Loosen the blade by turning the "T" handle (10) counterclockwise (CCW). The blade must be reasonably tight.

If this adjustment does not correct the problem, adjust the wheel pitch. Usually, adjusting the idler wheel will correct the problem. However, if it doesn't, both idler and drive wheels will have to be adjusted as follows:

1. Loosen blade tension until the blade is slack by turning the "T" handle CCW.
2. Raise the frame into the vertical position. See Diagram.
3. Loosen 2 cap screws 7A and 7B 1/2 turn.. Then tighten 2 cap screws 7C and 7D 1/2 turn.
4. Tighten blade by turning "T" handle CW. If the blade then runs in proper position on both wheels, no further adjustment is necessary.

If the blade runs back to the flange of the idler wheel and not on the drive wheel, make the following adjustment:

1. Loosen the 2 cap screws, 22E and 22F, at the motor end of the wheel plate.
2. Tighten the 2 Allen screws, 22G and 22H, about 1/2 turn.
3. Tighten all four cap screws.
4. Start the motor to see if the blade runs back to the flange of the wheel.

**CAUTION: Too much pitch will wear the wheel flanges and roll over the back of the blade!** This problem can usually be determined by the noise of the blade rubbing against the flange. To check further, place a piece of paper between the blade and the wheel. Start the saw. The blade should not shear the paper but just fold it over. If it shears the paper, back off the adjustment a little at a time until proper adjustment is reached.

## BLADE BRUSHES

Blade brushes should be cleaned frequently with kerosene or a good solvent. To take advantage of both rows of bristles, invert blade brushes and install them on the opposite side of the blade.

For best results, replace worn, filled or sticky brushes. When bolting brushes to the mounting angles, be sure wire bristles are turned in the same direction that the blade travels.

## BLADE GUIDE ADJUSTMENT

1. Check the blade fit between guide bearings by grasping the blade between the guide and the band wheel.
2. Twist blade back and forth.
3. If too much clearance is found, rotate the eccentric axle (34), page 12, until the bearing (32) is snug against blade and all clearance has been removed.
4. Check guide bearing (32) with thumb by applying force against bearing. It should be possible to rotate the bearing while it is snug against the blade and all clearance has been removed.
5. When looseness has been corrected, make another cut. If the cut is not straight, further adjustment must be made.
6. Place a square on the cut. Determine if the blade is cutting toward or away from the bed or if it is out of square with the vise.
7. If the vise is out of square, correct this by squaring the vise with the slot in the saw bed.
8. If the cut is out of square on the vertical dimension, correct this by moving the guides either away from or towards the saw bed. This is accomplished as follows:
  - a. Loosen the 2 cap screws (31), which hold the guide (28) to the guide brackets (23 & 37). Hold the guide from twisting and tap it in the desired direction until the blade is square with the saw bed. To do this:
    1. Place a spacer between the frame wheel guard and the switch box raising the blade teeth just over the saw bed.
    2. Place a machinist's square on the saw bed and move it to touch the body of the saw blade - making sure it does not touch the blade teeth.
    3. Use a feeler gauge, .002" or less, to see that the blade is square from top to bottom. If further adjustment is needed, loosen cap screws on one blade guide and rotate guide so the feeler gauge will not enter at top or bottom. Do not move guide sideways. This may move the blade out of square with the vise. Tighten cap screws.

## LUBRICATION

Correct and adequate lubrication is very important to achieve maximum service. It is imperative that all dust and dirt be removed before lubricating.

Marfak Grade "O" Grease, or equivalent, is used in the gear case. Other parts of the saw may be lubricated as follows:

1. Vise adjusting screw. Use a heavy oil or light grease.
2. Keep internal ring gear and pinion well lubricated with a good quality, medium grade, fibrous grease.
3. Wheel ball bearings are sealed and permanently lubricated.
4. For proper motor lubrication, follow the motor manufacturer's instructions.

## LUBRICATION SUMMARY

### GEAR CASE:

Service interval; inspect after 3 years and annually thereafter.

Lubricant: Mobilgrease XHP220 or equivalent.

**WISE SCREW, RING GEAR, PINION:** Inspect monthly  
Lubricant: Use Anti-seize on vise screw  
Use Extreme Pressure Open Gear Lube on ring and pinion gears sparingly.

## HELPFUL SUGGESTIONS

1. To select proper blade, consider the type of material to be cut as well as to its size and shape. The **SELECT-O-CHART** is a handy reference guide.
2. Use the correct blade speed and correct pressure for each type of material cut.
3. Always maintain proper blade tension.
4. Lower saw frame carefully so that the blade will start cutting before full frame feed pressure is applied to the blade.
5. Reduce feeding pressure for the first two or three cuts with a new blade.
6. Keep the adjustable blade guide as close as possible to the material being cut.
7. Keep blade brushes in contact with the blade teeth at all times.

### Recommended Service Kit for Insurance Against Downtime

	2 years	
100406-001	Bearing	6 req'd
100066-002	"V" Belt	1 req'd
M-426	Blade Brush	2 req'd

# Bed & Leg Details

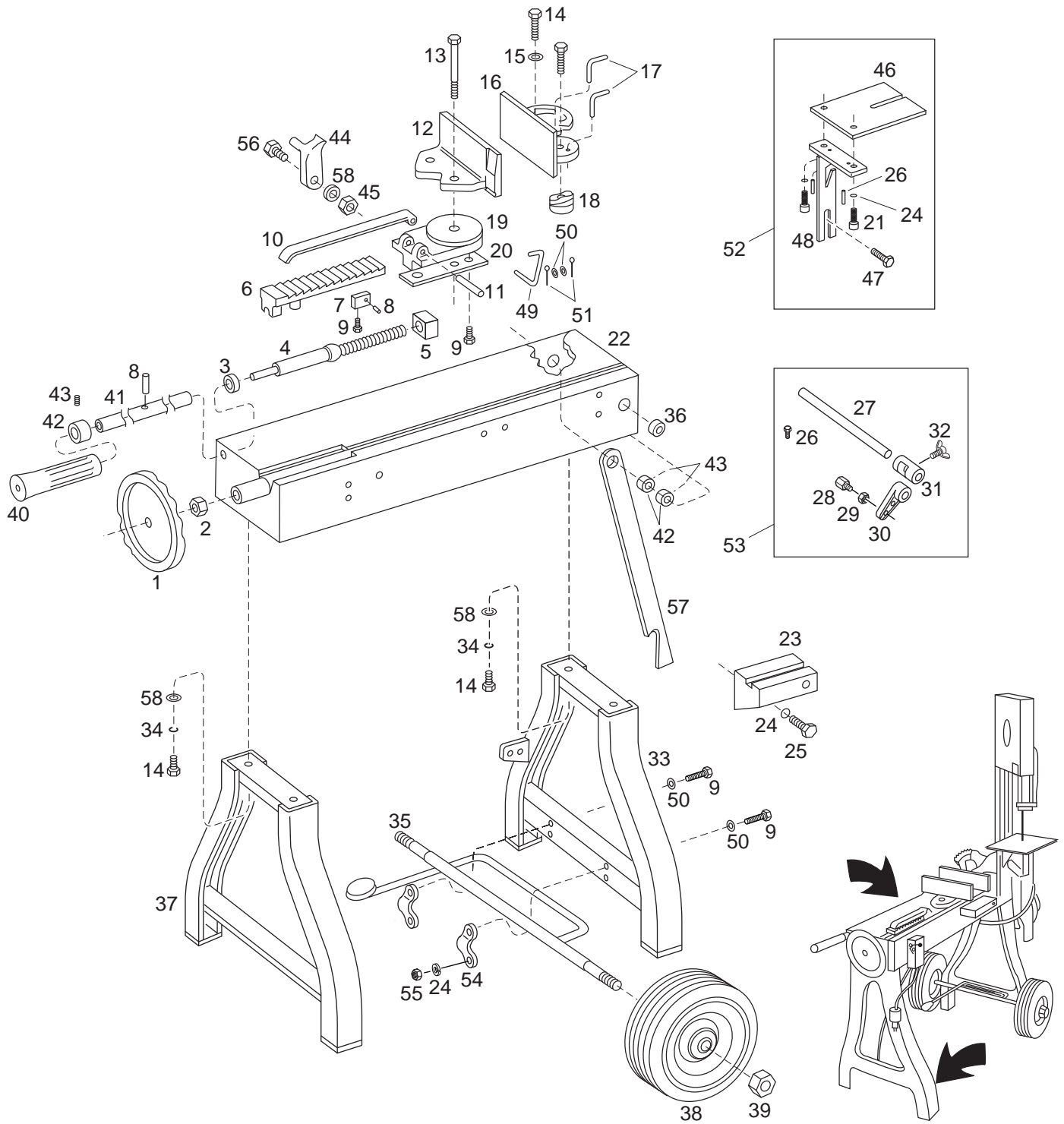



## Bed & Leg Details

Always give model number, serial number and part number when ordering parts.

1	A-016	HAND WHEEL	32	100042-017	THUMB SCREW, 5/16-18 X 1-1/4
2	100019-008	HEX JAM NUT, 3/4-10	33	120209	LEG, DRIVE END
3	100402	THRUST COLLAR	34	100025-005	LOCK WASHER, 1/2
4	102889	WISE SCREW	35	102932	WHEEL AXLE
5	M-061B	WISE SCREW NUT	36	100419-007	BUSHING (2 EACH)
6	102890	WISE RATCHET	37	120210	LEG, IDLE END
7	102957	CLAMP BLOCK	38	102938	WHEEL
8	100053-005	ROLL PIN, 3/16 X 1	39	100023-005	SELF-LOCKING NUT, 5/18-11
9	100004-020	CAP SCREW, HH, 5/16-18 X 1-1/4	40	105826	HANDLE GRIP
10	120232	WISE RATCHET DOG	41	105818	HANDLE ROD
11	100053-002	ROLL PIN, 3/8 X 2-1/2	42	102886	COLLAR
12	105847	MOVABLE VISE JAW	43	100034-001	SET SCREW, 1/4-20 X 3/16
13	100004-039	CAP SCREW, 1/2-13 X 2-1/2, HEX HEAD	44	102887	RATCHET DOG
14	100004-037	CAP SCREW, 1/2-13 X 1-1/2, HEX HEAD	45	100019-005	HEX JAM NUT, 1/2-13
15	155107	WISE WASHER	46	102923	TABLE PLATE
16	A-031	STATIONARY VISE JAW	47	100064-001	CAP SCREW, WASHER HEAD, 5/16-18 X 1
17	M-065	LOCATING PIN	48	102924	TABLE SUPPORT
18	A-151	CLAMP NUT	49	102955	STOP LATCH
19	105839	WISE SLIDE BLOCK	50	100030-004	FLAT WASHER, 5/16
20	105840	WISE SLIDE BLOCK GUIDE	51	100050-003	COTTER PIN, 1/8 X 1
21	100004-013	CAP SCREW, 5/16-18 X 5/8, HEX HEAD	<b>52 102922</b>		<b>TABLE ASSEMBLY (INCLUDES ITEMS 21, 24, 26, 46, 47 &amp; 48)</b>
22	105845	BED	<b>53 101709</b>		<b>STOP STOCK ASSEMBLY (INCLUDES ITEMS 26-32)</b>
23	101750	TIP OFF BLOCK	54	120201	AXLE MOUNTING STRAP
24	100025-002	LOCK WASHER, 5/16	55	101300	HEX NUT, 5/16-18
25	100004-063	CAP SCREW, 5/16-18 X 3/4, HEX HEAD	56	100008-010	CAP SCREW, 1/2-13 X 2-1/2, SOCKET HEAD
26	100034-003	SET SCREW, 5/16-18 X 3/8	57	120033	LATCH
27	A-062	STOP BAR	58	100030-007	FLAT WASHER, 1/2
28	100033-023	SET SCREW, 3/8-16 X 2-1/2			
29	100017-003	HEX NUT, 3/8-16			
30	A-013	STOP ARM	<b>102931</b>		<b>WHEEL AND HANDLE KIT FOR OLDER SAWS INCLUDES 35,38,40-42</b>
31	A-036	STOP ARM HOUSING			

# Wheel & Frame Details

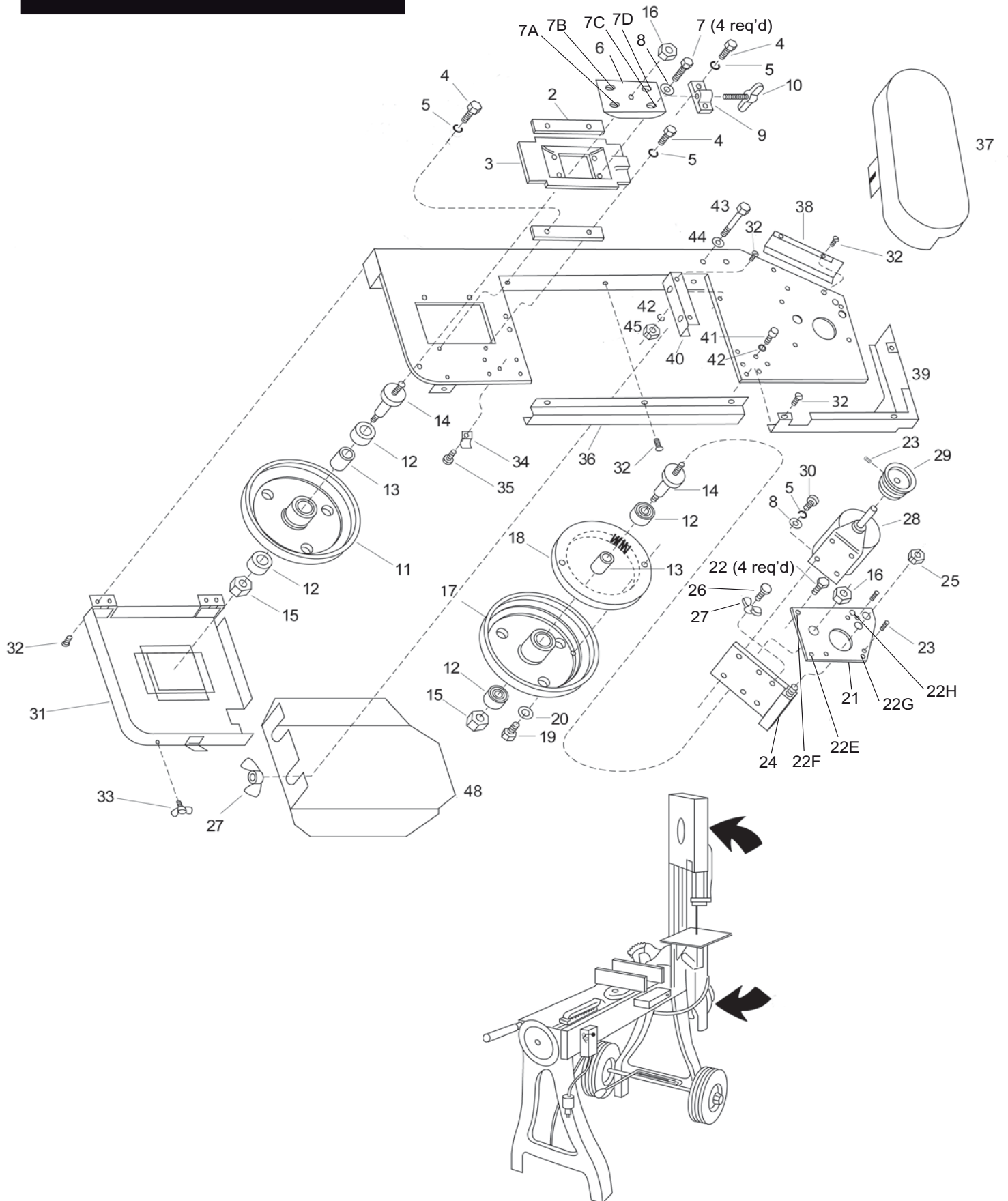

# Wheel & Frame Details

Always give model number, serial number and part number when ordering parts.

1	102874	FRAME	29	101238	PULLEY MOTOR
2	A-046	WHEEL SLIDE BLOCK	30	100004-012	CAP SCREW, 5/16-19 X 1/2, HEX HEAD
3	A-012	SLIDE BLOCK	31	102876	WHEEL GUARD
4	100004-013	CAP SCREW, 5/16-18 X 5/8, HEX HEAD	32	100000-017	MACHINE SCREW, 10-32 X 1/4
5	100025-002	LOCK WASHER, 5/16	33	100063	THUMB SCREW
6	A-010	WHEEL ADJUSTING BLOCK	34	100218-010	CLAMP
7	100004-019	CAP SCREW, 5/16-18 X 1-1/8, HEX HEAD	35	100000-025	MACHINE SCREW, 1/4-20 X 1/2
8	102360	SPACER	36	102877	BLADE GUARD
9	A-009	WING SCREW BLOCK	37	105530	BELT GUARD
10	102896	WING SCREW	38	105811	ANGLE WHEEL GUARD
11	A-017B	BAND WHEEL, IDLE END	39	105810	WHEEL GUARD, DRIVE END
12	100414-003	BEARING	40	102879	WHEEL GUARD SUPPORT
13	105415	SPACER	41	100004-026	CAP SCREW, 3/8-16 X 7/8, HEX HEAD
14	105420	WHEEL AXLE	42	100025-003	LOCK WASHER, 3/8
15	100019-016	HEX JAM NUT, 5/8-18	43	100004-067	CAP SCREW, 3/8-16 X 3, HEX HEAD
16	100065-007	HEX NUT, 5/8-18	44	100029-004	FLAT WASHER, 3/8
17	A-017A	BAND WHEEL, DRIVE END	45	100017-003	HEX NUT, 3/8-16
18	A-086	RING GEAR	46	<b>105423</b>	<b>WHEEL ASSEMBLY COMPLETE, IDLE END (INCLUDES ITEMS 11-14)</b>
19	100004-053	CAP SCREW, 1/4-20 X 1, HEX HEAD	47	<b>105422</b>	<b>WHEEL ASSEMBLY COMPLETE, DRIVE END (INCLUDES ITEMS 12-15, 17-20)</b>
20	100025-001	LOCK WASHER, 1/4	48	105615	DRIVE WHEEL GUARD
21	102900	WHEEL PLATE	49	105856	BLADE GUARD
22	100004-063	CAP SCREW, 5/16-18 X 3/4, HEX HEAD	50	<b>105858</b>	<b>WHEEL AND BLADE GUARD AS- SEMBLY (INCLUDES ITEMS 31 AND 49)</b>
23	100034-003	SET SCREW, 5/16-18 X 3/8			
24	102903	MOTOR SUPPORT			
25	100023-005	SELF LOCKING NUT, 5/8-11			
26	100042-010	THUMB SCREW			
27	100024-001	WING NUT, 1/4-20			
28	100846-016	1/2 HP MOTOR 115/60/1			
	100846-010	3/4 HP MOTOR 220/60/3 (OPTION)			

## WHEEL PITCH ADJUSTMENT

If the blade runs too low on wheels, it may be because of too much blade tension. Loosen the blade by turning the "T" handle (10) counterclockwise (CCW). The blade must be reasonably tight.

If this adjustment does not correct the problem, adjust the wheel pitch. Usually, adjusting the idler wheel will correct the problem. However, if it doesn't, both idler and drive wheels will have to be adjusted as follows:

1. Loosen blade tension until the blade is slack by turning the "T" handle CCW.
2. Raise the frame into the vertical position. See Diagram.
3. Loosen 2 cap screws 7A and 7B 1/2 turn.. Then tighten 2 cap screws 7C and 7D 1/2 turn.
4. Tighten blade by turning "T" handle CW. If the blade then runs in proper position on both wheels, no further adjustment is necessary.

If the blade runs back to the flange of the idler wheel and not on the drive wheel, make the following adjustment:

1. Loosen the 2 cap screws, 22E and 22F, at the motor end of the wheel plate.
2. Tighten the 2 Allen screws, 22G and 22H, about 1/2 turn.
3. Tighten all four cap screws.
4. Start the motor to see if the blade runs back to the flange of the wheel.

**CAUTION:** Too much pitch will wear the wheel flanges and roll over the back of the blade! This problem can usually be determined by the noise of the blade rubbing against the flange. To check further, place a piece of paper between the blade and the wheel. Start the saw. The blade should not shear the paper but just fold it over. If it shears the paper, back off the adjustment a little at a time until proper adjustment is reached.

# Blade Guide & Gear Box Details

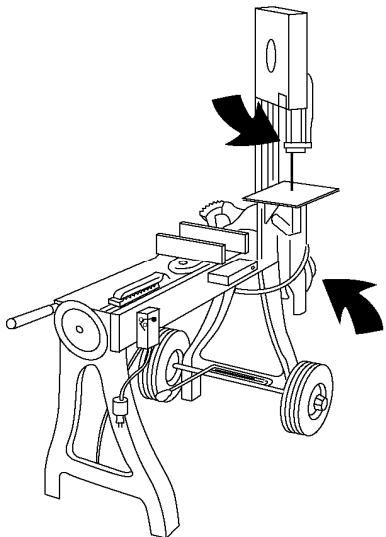
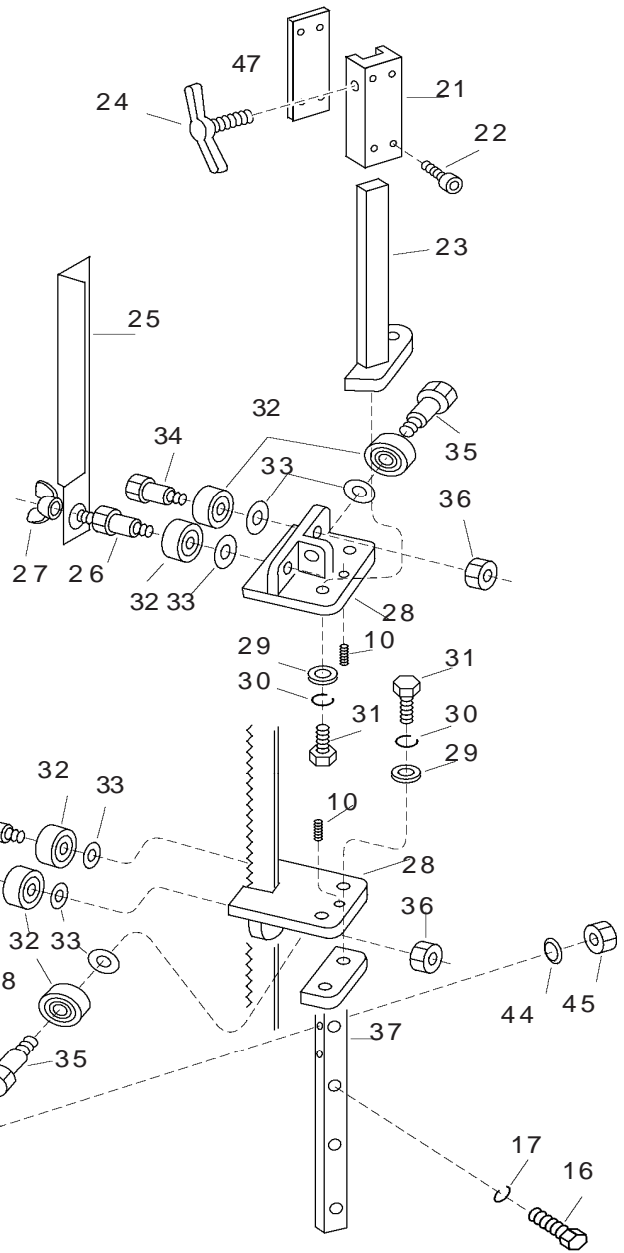
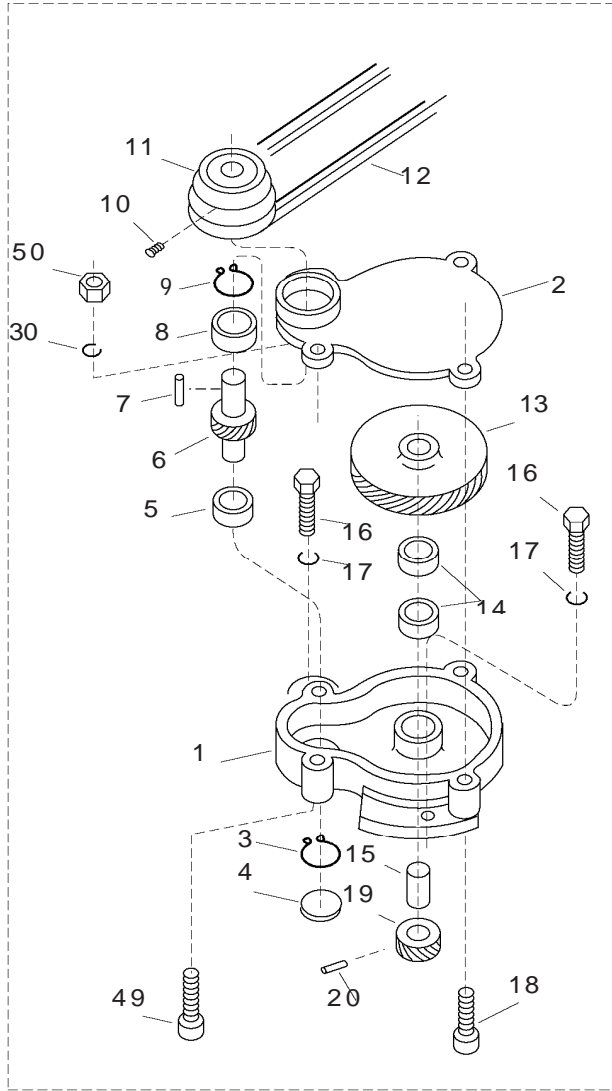

# Blade Guide & Gear Box Details

Always give model number, serial number and part number when ordering parts.

1	M-013	GEAR CASE	35	101298	ROLLER AXLE
2	101291	GEAR CASE COVER	36	101300	ECCENTRIC AXLE NUT
3	100068-001	SNAP RING, 3 REQ'D	37	102912	GUIDE BRACKET DE < S/N 11751
4	100072-001	EXPANSION PLUG		105830	GUIDE BRACKET - DRIVE END
5	100404-002	BALL BEARING			(SN -11752 - 23616)
6	101343	PULLEY SHAFT & PINION		120017	GUIDE BRACKET - DRIVE END
7	100056-001	KEY - 3/16 X 3/16 X 1			(AFTER SN 23617)
8	100414-003	BALL BEARING	38	105842	BLADE BRUSH ANGLE-LONG
9	100068-002	SNAP RING			BEFORE S/N 23617
10	100034-003	SET SCREW - 5/16-18 X 3/8 (NOT USED AFTER SN 23053)		105842-001	BLADE BRUSH ANGLE-LONG AFTER S/N 23617
11	101292	PULLEY	39	105844	BLADE BRUSH ANGLE - SHORT
12	100066-002	"V" BELT			BEFORE SN 23617
13	101286	DRIVEN GEAR		105844-001	BLADE BRUSH ANGLE-SHORT
14	100404-001	BALL BEARING			AFTER SN 23617
15	101644	DRIVE SHAFT	40	M-426	BLADE BRUSH
15A	100056-001	KEY FOR DRIVE SHAFT - 1/8 X 1/8 X 3/4 (NOT ILLUSTRATED)	41	100073-003	WELD BOLT - 1/4-20 X 1/2
16	100004-016	CAP SCREW - 5/16-18 X 7/8 - HEX HEAD	42	100017-001	HEX NUT - 1/4-20
17	100025-002	LOCK WASHER - 5/16	43	100013-011	CAP SCREW BUTTON HEAD 10-32 X 1-1/4-
18	100008-061	CAP SCREW - 1/4-20 X 1-1/2 - SOCKET HEAD	44	100027-003	LOCK WASHER #10
19	101645	DRIVE PINION	45	100147-004	KEPS NUT - 10-32
20	100180-001	COILED SPRING PIN	46	102949	STATIONARY BLADE GUARD
21	JK-057	SLIDE BLOCK	47	105885	SLIDE BLOCK SHIM
22	100008-003	CAP SCREW - 1/4-20 X 3/4 - SH	49	100000-047	ROUND HD MACH SCR 1/4-20 X 2"
23	102908	GUIDE BRACKET BEFORE S/N11751		<b>102901</b>	<b>GEAR BOX ASSEMBLY -</b> INCLUDES ITEMS 1-9 & 13-20
	105832	GUIDE BRKT IE S/N 11752-11884		<b>101643</b>	<b>DRIVE SHAFT &amp; PINION -</b> INCLUDES ITEMS 15, 19 & 20
	105853	GUIDE BRACKET - IDLE END (SN 11885-23616)		<b>105841</b>	<b>BLADE BRUSH ASSY INSIDE -</b> ITEMS 38, 41 & 42 before sn 23617
	120018	GUIDE BRACKET - IDLE END (AFTER SN 23617)		<b>105841-001</b>	<b>BLADE BRUSH ASSY INSIDE</b> after sn 23617
24	102898	WING SCREW		<b>105843</b>	<b>BLADE BRUSH ASSY OUT SIDE -</b> ITEMS 39-45 before sn 23617
25	105856	MOVEABLE BLADE GUARD		<b>105843-001</b>	<b>BLADE BRUSH ASSY OUTSIDE</b> after sn 23617
26	105860-001	ROLLER AXLE - IDLE END		<b>101322-001</b>	<b>ROLLER SUPPORT ASSEMBLY -</b> <b>DRIVE 1/2"</b> - INCLUDES ITEMS 28 & 32-36
27	100024-005	WING NUT - 1/4-20		<b>105591-001</b>	<b>ROLLER SUPPORT ASSEMBLY -</b> <b>IDLE 1/2"</b> - INCLUDES ITEMS 26, 28, 32-36
28	101297-001	ROLLER SUPPORT 1/2"			
	101297-002	ROLLER SUPPORT 3/4" See below			
29	100029-002	FLAT WASHER - 1/4			
30	100025-001	LOCK WASHER - 1/4			
31	100004-053	CAP SCREW - 1/4-20 X 1 - HEX HEAD			
32	100406-001	BALL BEARING			
33	100097-001	FLAT WASHER			
34	101299	ECCENTRIC ROLLER AXLE			

## If you have 3/4" Blade Guide Option

	101322-002	Roller Support Assy Drive 3/4"	
	105591-002	Roller Support Assy Idle 3/4"	
32	100416-001	Side Bearing	4 req'd
26	120234	Roller Axle	1 req'd
35	B-043	Roller Axle	1 req'd
34	B-109	Eccentric Roller Axle	2 req'd

# Coolant, Switch & Dash Pot Details

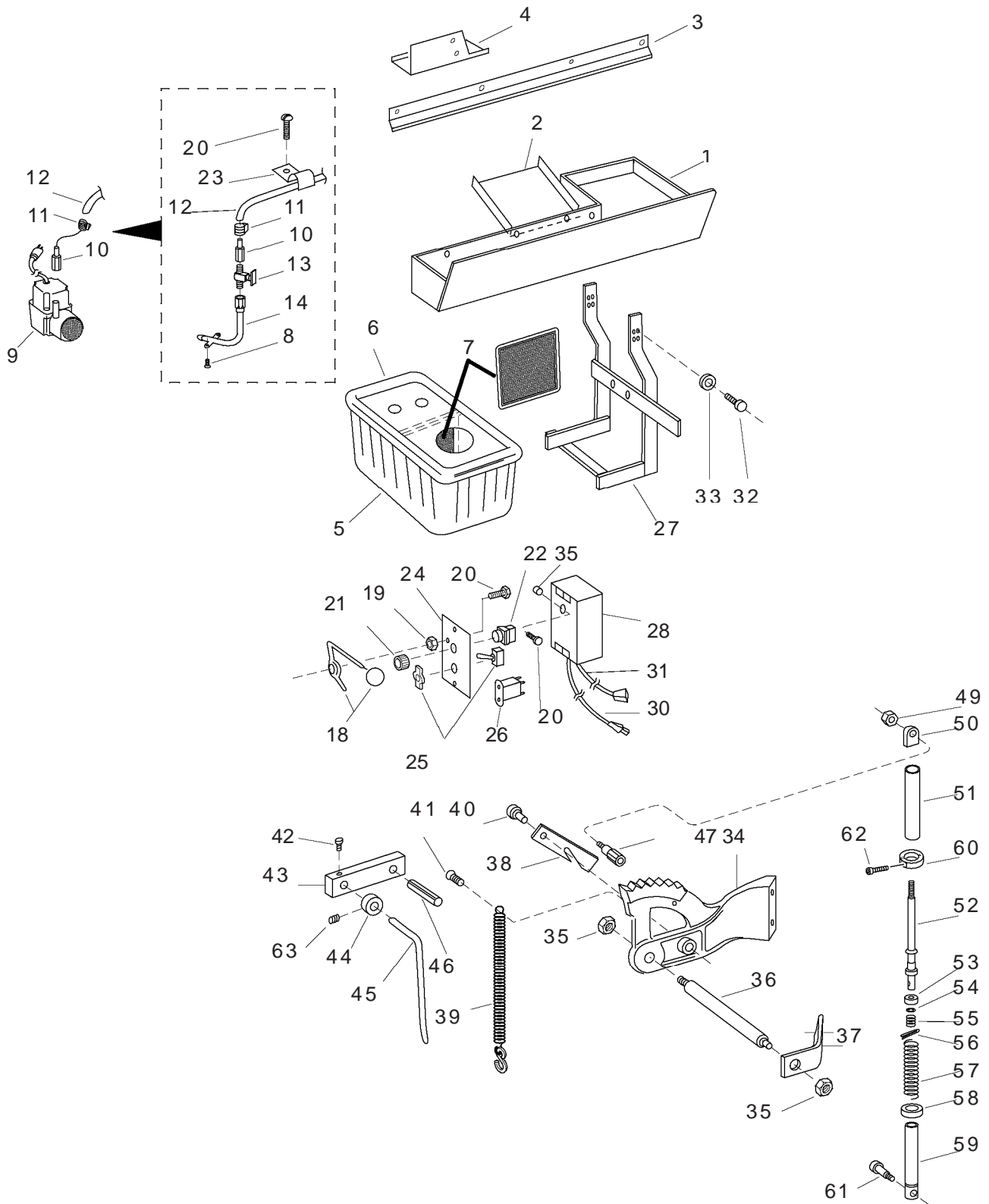

# Coolant, Switch & Dash Pot Details

Always give model number, serial number and part number when ordering parts.

1	120064	CHIP PAN	102858	FRAME RATCHET (USED BEFORE 11752)
2	120041	SPLASH GUARD		
3	120231	DRIP EDGE	35	100017-007 HEX NUT, 5/8-11
4	120230	DRIP PAN	36	102885 PIVOT BAR
5	120160-001	COOLANT TANK	37	120012 FRAME PIVOT BRACKET (USED AFTER 23616)
6	120162	COOLANT TANK COVER		
7	101565-009	SCREEN		105829 FRAME PIVOT BRACKET (USED UP TO SN 23616)
8	100000-017	ROUND HEAD MACHINE SCREW		
9	100249-010	COOLANT PUMP	38	120134 LATCH
10	102617	ADAPTER	39	105881 SPRING WITH "S" HOOK
11	100219-001	HOSE CLAMP	40	102895 STUD
12	100220-020	COOLANT HOSE, 3/8 X 96"	41	101311 FRAME SPRING ANCHOR
13	105780	VALVE (USED AFTER SN 23053)	42	100034-025 SET SCREW, 1/4-20 X 3/8
14	102984	COOLANT NOZZLE ASSEMBLY	43	120133 STOP BLOCK WITH SET SCREW
16	<b>120229-00?</b>	<b>SWITCH BOX ASSEMBLY</b> (INCLUDES ITEMS 18-31 LESS 27) <b>-002</b> 58B WET 115V <b>-003</b> 58B DRY 115V <b>-004</b> 58B DRY 230V <b>-005</b> 58B WET 230V	44	M-107 COLLAR WITH SET SCREW
			45	120135 RELEASE LEVER
			46	100053-010 ROLL PIN, 3/8 X 1-1/2
			47	M-155 DASH POT UPPER STUD
			48	N/A
			49	100017-003 HEX NUT, 3/8-16
<b>17</b>	<b>120228</b>	<b>SWITCH ASSEMBLY 115V</b>	50	M-144 PISTON ROD END
	120228-001	SWITCH ASSEMBLY 230V (INCLUDES ITEMS 18-26)	51	101524 OUTSIDE TUBE
18	105584-002	SWITCH LEVER WITH KNOB	52	101527 PISTON ROD
19	100017-001	HEX NUT, 1/4-20	53	M-166 CUP LEATHER
20	100004-053	CAP SCREW, 1/4-20 X 1, HEX HEAD	54	100070 CUP WASHER
21	100851-001	PUSH BUTTON GUARD	55	M-148 SPRING
22	100805-001	RESET SWITCH	56	100050-002 COTTER PIN, 3/32 X 3/4
23		CLAMP	57	102918 SPRING
24	105959	SWITCH BOX COVER	58	101777 WASHER
25	100674-006	TOGGLE SWITCH	59	101523 INSIDE TUBE
26	100866	RELAY	60	101776 CLAMP WITH BOLT
27	120211	COOLANT TANK BRACKET	61	M-147 LOWER STUD
28	105889	SWITCH BOX	62	100000-025 MACHINE SCREW, 1/4-20 X 1/2, ROUND HEAD
30	105961	CORD & PLUG	<b>63</b>	<b>M-301 DASH POT ASSEMBLY</b> (INCLUDES ITEMS 50-61, LESS 59 & 60)
31	100755-001	CORD SET, 115V FOR COOLANT		
32	100004-018	CAP SCR, 5/16-18 X 1, HEXHEAD	<b>64</b>	<b>101526 PISTON ROD ASSEMBLY COMPLETE</b> (INCLUDES ITEMS 52-56)
33	100030-004	FLAT WASHER, 5/16		
34	120217	FRAME RATCHET (USED AFTER SN 23616)	098049-001	DASH POT OIL (FILL TO 1" FROM TOP)
	105828	FRAME RATCHET (USED BETWEEN 11752 & 23616)		

## Coolant System for Field Installation order Part # 120218

This kit includes all parts to convert a  
Model 58BD to 58BW

# 58B Service Parts Changes

## ELECTRICALS

Before 17240 to 21035	100670-1 (Switch Only) or 102888 Switch Box Assembly
Beginning 20855	105869 Safe Start Plus and Cord Set
Beginning 21036	120228 Switch Assembly & 100846-16 Motor

## BLADE GUIDES

To Serial Number 11751	102858	Frame Ratchet
	102908	Guide Bracket Idle End
	102912	Guide Bracket Drive End
	101322	Roller Guide Assembly
From Serial Number 11752	105828	Frame Ratchet
	105832	Idle Guide Bracket End
	105830	Guide Bracket Drive End
	101322	Roller Guide Assembly

## BLADE GUARDS

To Serial Number 11885	102963	Blade Guard Idle End
	102949	Blade Guard Drive End
	102961	Pivot Rod

Current Idle Wheel Guard Assembly could replace old assembly using the following parts:

105868	Idle Wheel Guard Assembly
105860	Roller Axle

## WHEEL KITS

To Serial Number 22020	102931	Wheel and Handle Kit for field installation
------------------------	--------	---

## 120229-00? Switch Box Assembly

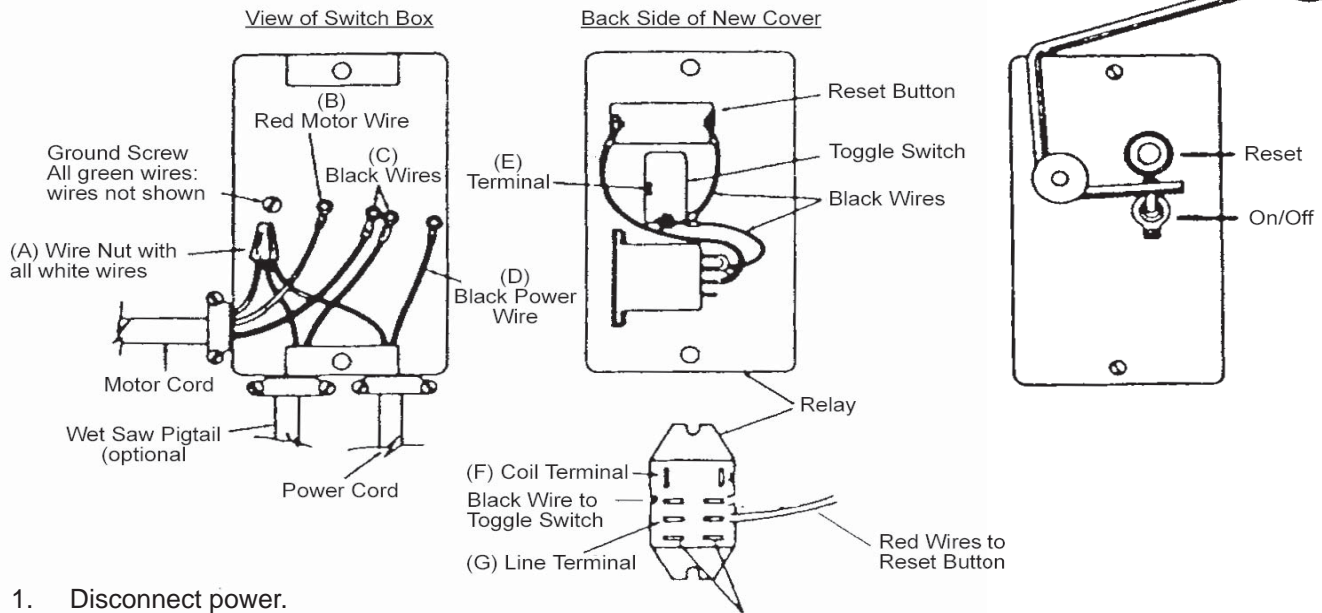

1. Disconnect power.
2. Remove existing cover.
3. Remove wire nut (A) and add white pigtail with push connector.
4. Cut off red motor wire (B) from both ends of motor cord.
5. Connect black wire (C) from motor and wet saw pigtail (C) to toggle switch terminal (E).
6. Cut off existing terminal on black power wire (D) and replace with push terminal supplied.
7. Connect new white pigtail to relay coil terminal (F).
8. Connect black power wire (D) with new push terminal to relay line terminal (G)
9. Install cover on switch box.
10. Saw operation. Push reset button only after loss of power. Normal saw operation is by toggle switch.



---

# Trouble Shooting

---

## For Greater Service and Efficiency Careful Operation - Blade Consideration

<b>Cutting out of line</b>	<i>Too heavy a feed or worn blade</i>	Reduce feed rate by adjusting frame weight or replace blade. Replace worn guide bearings when they begin to show excessive wear
	<i>Guides in wrong position</i>	Set as close to work as possible
	<i>Guides out of alignment</i>	Follow adjustment instructions
	<i>Set worn on one side of blade</i>	Keep brushes clean. Avoid teeth rubbing in cut by applying enough weight so that each tooth is cutting a good chip
	<i>Starting cut on odd shape where blade does not contact flat surface</i>	Retard feed until blade has a good start in the material
<b>Stripping teeth</b>	<i>Blade teeth too coarse</i>	Be sure that two or more blade teeth are in contact with material being cut
	<i>Hard spots on material</i>	Rotate stock, if possible. Do not put new blade in cut at same angle
<b>Breaking</b>	<i>Guides out of alignment</i>	Follow adjustment instructions.
	<i>Blade twisting</i>	Adjust guides as close to work as possible. Be sure material being cut is held firmly
	<i>Lack of blade tension</i>	Always keep blade tight
	<i>Dash Pot malfunction</i>	Check hydraulic fluid level and/or condition of cup leather
<b>Excessive wear</b>	<i>Blade speed too fast.</i>	Follow recommended cutting speeds
<b>Blade running off wheel</b>	<i>Lack of blade tension</i>	Always keep blade tight
	<i>Improper wheel pitch adjustment</i>	See instructions for wheel pitch adjustment

**Always use a light feed on new blades!**

# ELECTRICAL SCHEMATIC

## 120V / 240V (CURRENT VERSION)

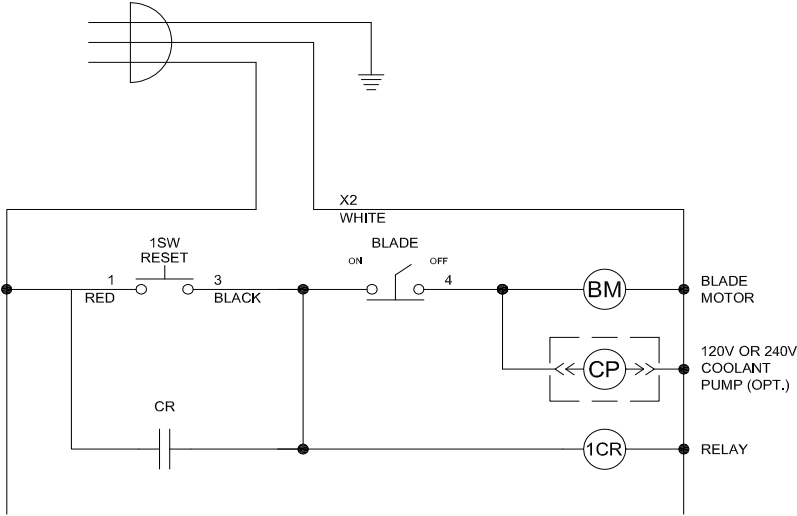

## 240V (PREVIOUS VERSION)

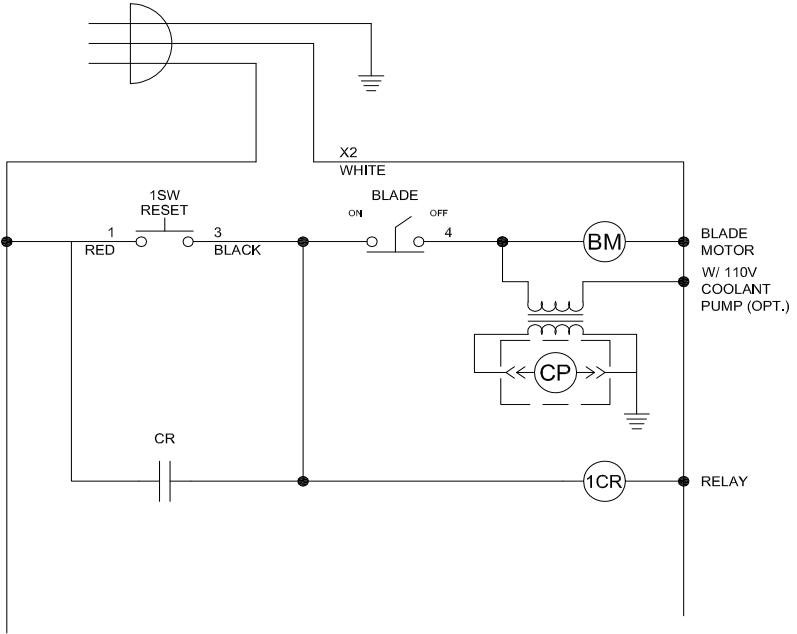



# Wellsaw® Select-O-Chart

To assist in selecting the right blade and the right speed for your job!

Speed = Suggested blade speed in feet-per-minute

Feeding pressure: L = light, M = medium, H = heavy • T = teeth per inch

Material (Annealed)	Blade Speed (SFPM)	Cutting Rate (SIPM)	Blade Speed (SFPM)	Cutting Rate (SIPM)	Blade Speed (SFPM)	Cutting Rate (SIPM)	Blade Speed (SFPM)	Cutting Rate (SIPM)
<u>Carbon Steels</u>								
1008-1013	250	8 - 10	275	9 - 12	280	12 - 15	250	9 - 12
1015-1018	250	8 - 10	275	9 - 12	250	12 - 15	230	9 - 12
1048-1065	200	5 - 7	200	5 - 7	175	8 - 10	150	6 - 8
1065-1095	200	4 - 6	200	5 - 7	150	6 - 8	120	6 - 8
<u>Free Machining Steels</u>								
1108-1111	300	9 - 11	330	12 - 14	275	13 - 15	220	11 - 14
1112-1113	300	8 - 11	330	11 - 13	275	12 - 15	220	12 - 15
1115-1132	300	7 - 11	330	10 - 13	275	13 - 16	220	11 - 14
1137-1151	275	6 - 8	250	8 - 10	250	8 - 11	200	7 - 10
1212-1213	300	8 - 10	320	11 - 13	300	13 - 15	255	11 - 14
<u>Manganese Steels</u>								
1320-1330	250	5 - 7	250	5 - 8	200	8 - 11	175	7 - 10
1335-1345	250	5 - 7	225	5 - 7	200	7 - 9	175	5 - 8
<u>Nickel Chrome Steels</u>								
3115-3130	260	4 - 6	260	5 - 7	230	5 - 7	225	5 - 7
3135-3150	220	4 - 6	200	4 - 7	180	6 - 8	150	5 - 8
3310-3315	200	3 - 4	180	4 - 5	180	5 - 7	160	4 - 6
<u>Molybdenum Steels</u>								
4017-4024	300	3 - 5	270	4 - 7	250	6 - 8	220	5 - 8
4032-4042	300	3 - 5	270	4 - 7	250	6 - 8	230	5 - 8
4047-4068	250	3 - 5	220	4 - 6	200	5 - 7	180	3 - 5
<u>Chrome Moly Steels</u>								
4130-4140	280	4 - 6	250	5 - 8	250	8 - 10	220	6 - 8
4142-4150	230	3 - 5	200	4 - 6	200	5 - 7	170	4 - 6
<u>Nickel Chrome Moly Steels</u>								
4317-4320	250	3 - 5	225	4 - 6	200	5 - 7	170	4 - 6
4337-4340	230	3 - 4	200	4 - 5	200	4 - 6	170	4 - 5
8615-8627	250	4 - 5	230	6 - 7	230	6 - 8	200	6 - 7
8630-8645	250	3 - 5	230	4 - 6	230	5 - 7	180	4 - 6
8647-8660	220	2 - 4	200	3 - 5	200	4 - 6	150	3 - 5
8715-8750	250	3 - 5	220	4 - 6	220	5 - 7	180	4 - 6
9310-9317	200	1 - 3	160	2 - 3	160	2 - 4	150	2 - 3
9437-9445	250	4 - 5	230	4 - 5	230	5 - 6	180	4 - 5
9747-9763	250	2 - 4	230	3 - 5	200	4 - 6	180	3 - 5
9840-9850	240	4 - 5	220	4 - 6	200	5 - 7	180	4 - 6
<u>Nickel Moly Steels</u>								
4608-4621	250	3 - 5	220	5 - 6	220	6 - 7	200	5 - 6
4640	220	3 - 5	200	4 - 6	200	5 - 7	170	4 - 6
4812-4820	200	3 - 5	180	3 - 5	180	4 - 6	160	4 - 5
<u>Chrome Steels</u>								
5045-5046	280	4 - 6	250	5 - 7	250	8 - 10	200	7 - 8
5120-5135	280	4 - 6	250	6 - 7	240	7 - 8	180	5 - 8
5140-5160	250	3 - 5	230	4 - 6	230	5 - 7	200	4 - 6
50100-52100	180	2 - 4	160	3 - 5	150	4 - 6	100	3 - 5
<u>Chrome Vanadium Steels</u>								
6117-6210	225	4 - 5	225	5 - 7	200	6 - 8	170	5 - 7
6145-6152	225	3 - 4	200	4 - 5	200	5 - 6	150	4 - 5
<u>Die Steels</u>								
A-2	210	2 - 3	200	3 - 4	190	3 - 4	180	2 - 3
D-2, D-3	110	1 - 2	100	1 - 2	90	1 - 2	80	1 - 2
D-7	90	1	80	1	70	1	70	1
O-1, O-2	240	3 - 4	210	4 - 5	190	5 - 6	170	4 - 5
O-6	230	3 - 4	200	4 - 6	180	5 - 7	150	4 - 6

Material (Annealed)	Blade Speed (SFPM)	Cutting Rate (SIPM)	Blade Speed (SFPM)	Cutting Rate (SIPM)	Blade Speed (SFPM)	Cutting Rate (SIPM)	Blade Speed (SFPM)	Cutting Rate (SIPM)
<u>Silicon Steels</u>								
9255-9260	200	2 - 4	180	3 - 5	180	3 - 5	150	3 - 5
9261-9262	200	1 - 3	160	2 - 3	160	2 - 4	150	2 - 3
<u>High Speed Tool Steels</u>								
T-1, T-2	130	1 - 2	110	2 - 3	100	2 - 4	90	2 - 3
T-4, T-5	110	1 - 2	100	1 - 2	90	2 - 3	80	1 - 2
T-6, T-8	110	1 - 2	100	1 - 2	80	1 - 2	70	1 - 2
T-15	80	1	80	1	70	1	50	1
M-1	150	1 - 3	140	2 - 4	130	3 - 5	110	2 - 4
M-2, M3	120	1 - 2	110	2 - 3	100	3 - 4	80	2 - 3
M-4, M-10	100	1 - 2	90	1 - 2	80	1 - 3	60	1 - 2
<u>Hot Work Steels</u>								
H-12, H-13, H-21	150	2 - 4	125	3 - 5	125	2 - 4	125	2 - 4
H-22, H-24, H-25	150	1 - 3	125	1 - 3	125	1 - 3	125	1 - 3
<u>Shock Resisting Tool Steels</u>								
S-1	220	2 - 4	180	3 - 5	165	3 - 5	150	2 - 4
S-2, S-5	170	1 - 3	150	3 - 5	120	2 - 4	100	1 - 3
<u>Special Purpose Tool Steels</u>								
L-6	200	2 - 4	180	3 - 5	170	3 - 5	150	2 - 4
L-7	200	2 - 4	180	3 - 5	150	3 - 5	100	2 - 4
<u>Stainless Steels</u>								
201, 202, 302, 304	120	2 - 4	100	2 - 4	100	2 - 4	100	1 - 3
303, 303F	140	2 - 4	120	2 - 4	100	3 - 5	100	2 - 4
308, 309, 310, 330	90	1	70	1	60	2	60	1
314, 316, 317	90	1	80	1	70	2	60	1
321, 347	130	1 - 3	110	1 - 3	100	2 - 4	80	1 - 3
410, 420, 420F	150	1 - 3	130	1 - 3	120	2 - 4	100	1 - 3
416, 430F	200	3 - 5	180	4 - 6	170	5 - 7	150	4 - 6
430, 446	100	1 - 3	90	2 - 4	80	2 - 4	80	1 - 3
440 A,B,C	120	1 - 3	10	1 - 3	90	2 - 4	70	1 - 3
440F, 443	150	1 - 3	130	1 - 3	120	2 - 4	100	1 - 3
17-4PH, 17-7PH	100	2 - 3	90	2 - 4	80	3 - 4	80	2 - 3
A-7	100	1 - 2	100	1 - 2	100	2 - 3	100	2 - 3
<u>Beryllium Copper #25</u>								
BHN 100-120	350	4 - 6	300	5 - 7	275	6 - 8	225	5 - 7
BHN 220-250	250	2 - 4	225	3 - 5	200	3 - 4	175	3 - 5
BHN 310-340	200	1 - 2	160	1 - 2	140	2 - 3	100	1 - 2
<u>Nickel Base Alloys</u>								
Monel	100	1 - 2	100	1 - 2	80	1 - 2	60	1
R Monel	140	2 - 3	140	2 - 4	125	2 - 4	75	2 - 3
K Monel	100	1	80	1	60	1	60	1
KR Monel	100	1 - 3	90	1 - 3	80	1 - 3	60	1 - 2
Inconel	110	1 - 2	100	1 - 3	80	1 - 3	80	1 - 2
Inconel X	90	1	80	1	70	1	60	1
Hastelloy A	120	1 - 2	100	1 - 2	85	2 - 3	75	1 - 2
Hastelloy B	110	0 - 1	100	1 - 2	90	1 - 2	75	0 - 1
Hastelloy C	100	0 - 1	90	0 - 1	70	0 - 1	60	0 - 1
Rene 41	90	1	90	1	90	1 - 2	90	1 - 2
Udimit	100	1	90	1 - 2	90	1 - 2	90	1 - 2
Waspalloy	90	1	90	1 - 2	90	1 - 2	90	1 - 2
Titanium	100	1 - 2	100	2 - 3	100	2 - 3	100	2 - 3
<u>Titanium Alloys</u>								
TI-4AL-4MO	100	0 - 1	90	0 - 1	80	0 - 1	70	0 - 1
TI-140A2CR-2MO	100	0 - 1	90	0 - 1	80	0 - 1	60	0 - 1

The Original.....Since 1926



2829 N. Burdick St.  
Kalamazoo, MI 49004  
Phone: 269-345-1132  
Fax: 269-345-0095  
website: [www.wellsaw.com](http://www.wellsaw.com)  
email: [parts@wellsaw.com](mailto:parts@wellsaw.com)